

## Dome Fiber Optic Splice Closure

### CV007 Instruction Manual



#### Description:

CV007 dome type fiber optic splice closure provide space and protection for fiber optic cable splicing and joint. It is made of high quality ABS material and sealed with silicon Gum material. It is water & dust proof and suitable for aerial, duct, wall-mounted or pole mounted applications. The closure can be opened and used again, no need to change the sealing material after it be sealed.

It is produced as per telecom standard YD/T 814.1-2004, suitable for optical fiber splicing in PON, FTTX etc.

#### Specification:

##### Main electrical technical parameters

Protection grounding device:

Insulation resistance:  $\geq 2 \times 10^4 \text{M}\Omega/500\text{V}$  (DC)

Withstanding Voltage:  $\geq 15000\text{V}$  (DC) /1min, no breakdown, no flash over.

##### Main mechanical performance parameters

Extrude: Withstand  $>600\text{N}$  Axial tension

Squash: Withstand pressure  $1500\text{N}/100\text{mm}$

Shock: Withstand  $16\text{N}\cdot\text{m}$ , 3 times

Bending: The closure and connection between closure cover & base can withstand bending tension  $150\text{N}$ , bending angel  $\pm 45^\circ$ , 10 cycles.

##### The basic structure and dimensions

CV007 has 6 round ports or 1 oval port + 4 round port (see below picture)

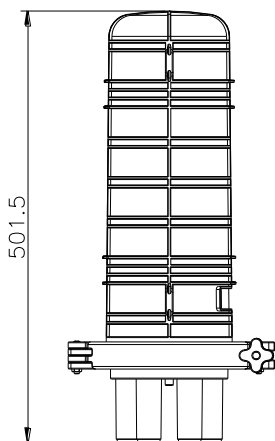
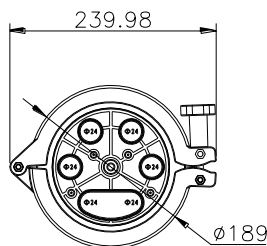
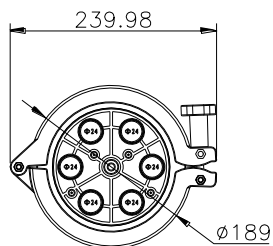

6 round ports

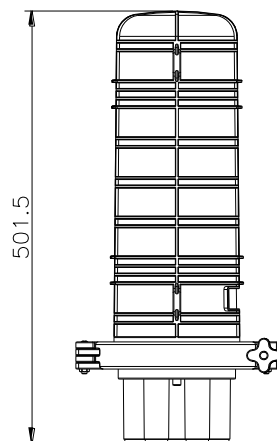

1 oval port & 4 round ports

**Working principle:**

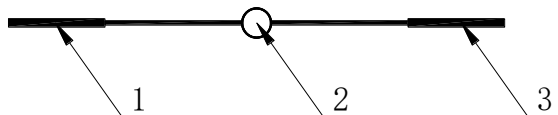

1—fiber cable    2—splicing connection    3—fiber cable

**Structure:**

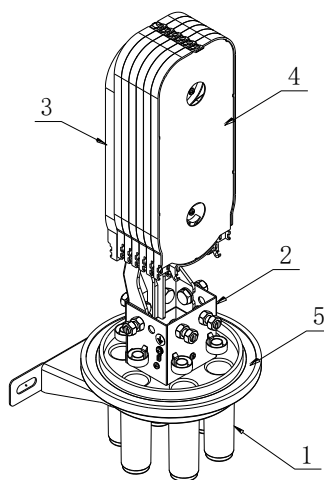
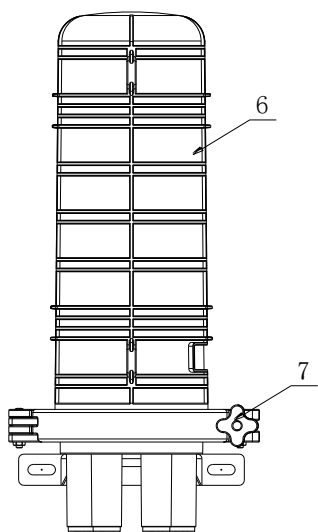

1--base    2--cable fixing board    3--cable storage tray    4--fiber splice tray    5--sealing ring  
6--closure body    7--hook

### Features:

Aerial, pole mounted, wall-mounted, duct installation.

Plastic parts are made of high-quality anti-aging plastic, metal parts are made of high-quality rust-proof materials.

Easy installation for closure sealing & cable entry/exit sealing.

Reasonable design for fiber bending radius, enough fiber storage space.

Big storage space for fiber splice tray, rotary angel more than 90°, easy for installation & maintainance.

Can install grounding device and valve.

Long service life of up to 25 year.

IP standard: IP68

### Environment:

Operating temperature: -40°C~+65°C

Storage temperature: -25°C~+65°C

Relative humidity: ≤85% (+30°C)

Atmospheric pressure: 70~106kPa

### Installation & adjustment:

**1. Check the closure & accessories are in good condition.**

**2. Prepare the installation tool**

**3. Installation**

CV007 dome type fiber optic splice closure can be aerial and pole-mounted installation.

#### Aerial mounted

Fix the hook on the closure body, then hang the other side of hook on steel wire. (See below picture)

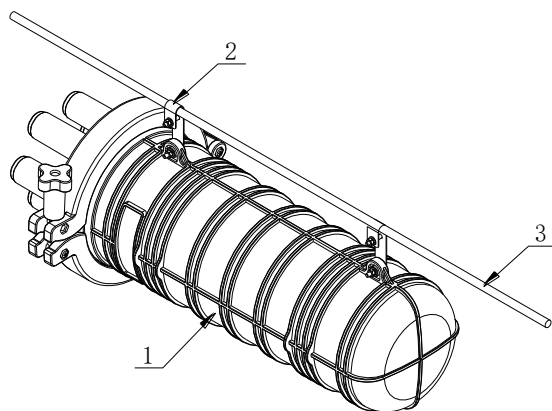

1--closure 2—aerial hook 3—steel wire

#### Pole mounted

Fix the pole mounted plate on closure, then install the "U" screw bolt on pole. (See below picture)

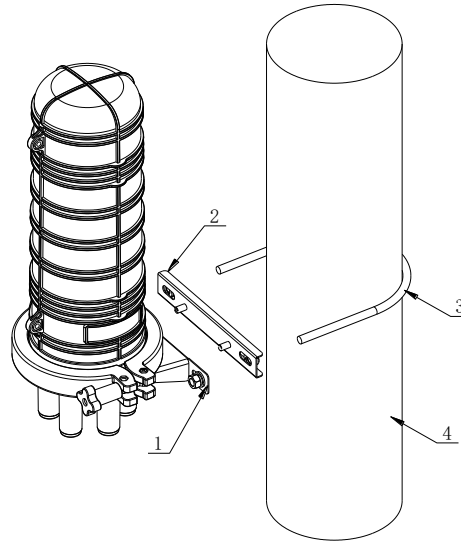

1—pole mounted fixing plate    2—plate    3—“U” screw bolt    4—steel wire

### Using & operation:

1. Please read the instruction.
2. Open the anchor ear, then open the closure.
3. Make sure the length of cable that fixing inside. (See below picture)

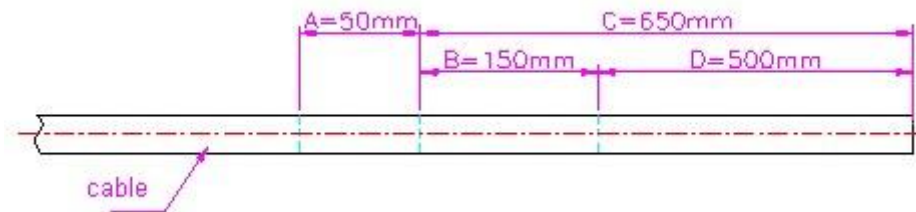

A—Length of fixing cable when entry closure    B—Length of cable  
C—Length of cable inside closure    D—Length of lead out fiber

4. Strip the cable jacket, the length can be checked as your using condition or as per above picture.
5. Open the cable entry port by saw blade. (See below picture)

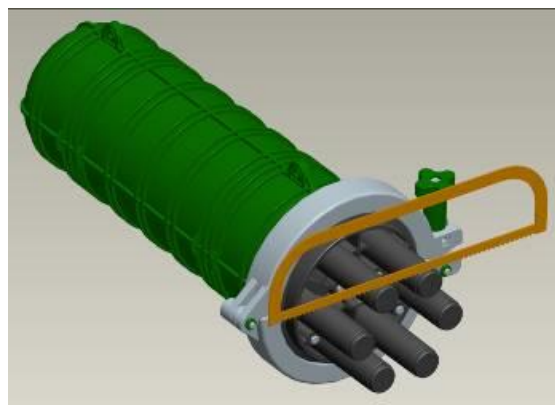

6. Cable installation

Put the stripped cable go through the heat sleeve and entry cable port. (See below picture)

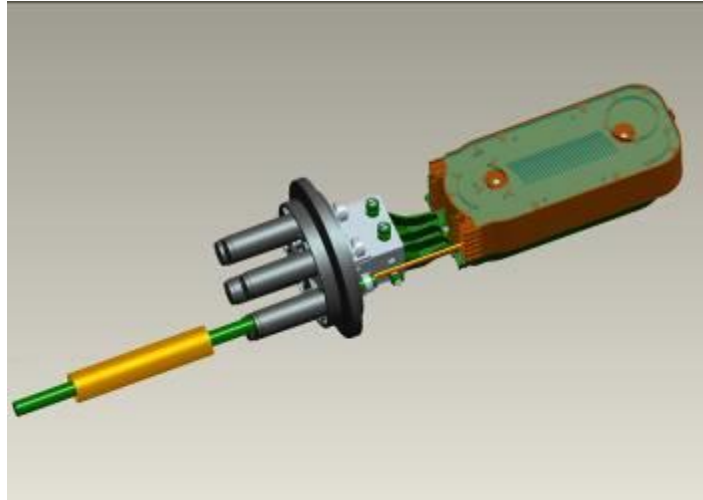

Fix the strengthen core on closure and use clamp fixing cable (see the picture)

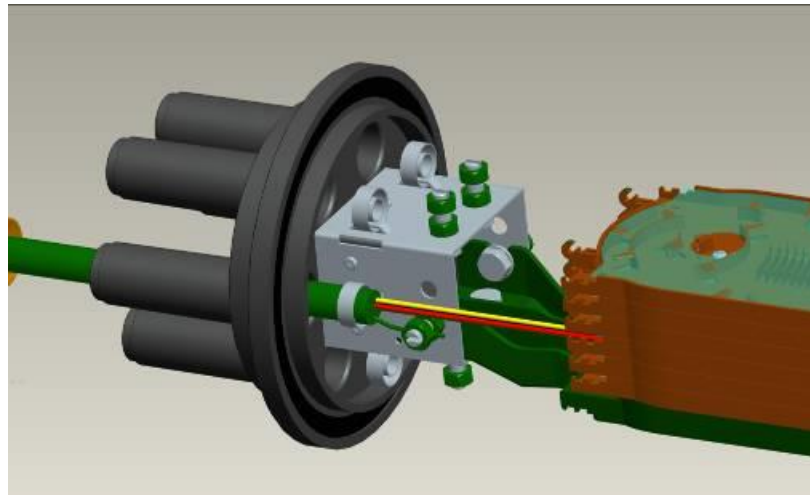

Arrange the fiber entry splice tray and do splicing. (See the picture)

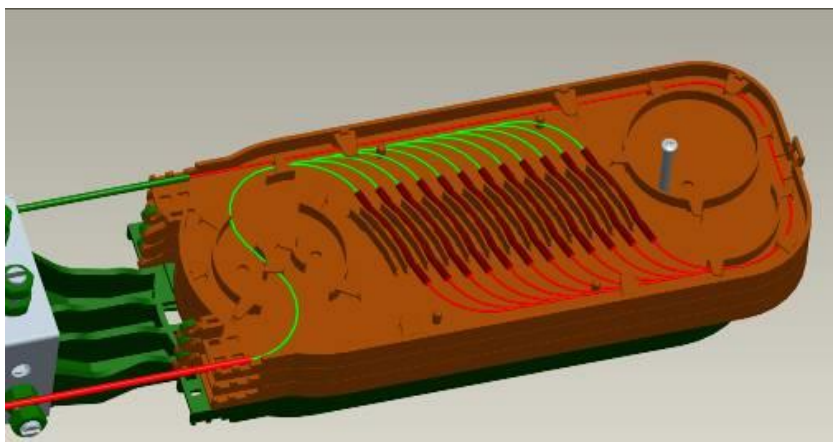

7. Install fiber optic splitter & optical adapter

CV007 dome type fiber optic closure can install 2pcs steel tube PLC splitters.

Working principle(see below picture)

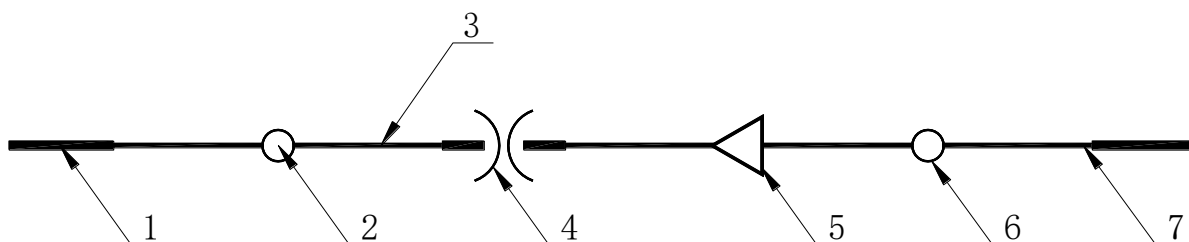

1—optical cable 2—splicing connection 3—fiber pigtail 4—Optical adapter  
5—PLC splitter(steel tube type) 6—splicing connection 7—optical cable

The location of fiber optic splitter & optical adapter (See the picture).

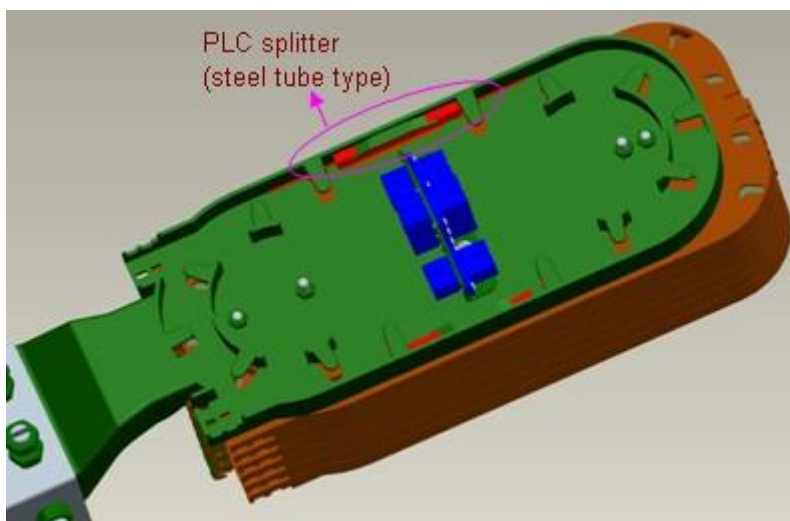

8. Shrinkable tube sealing

Remark on cable, then use sandpaper polish the location that will be packed by shrinkable tube. (See the picture)

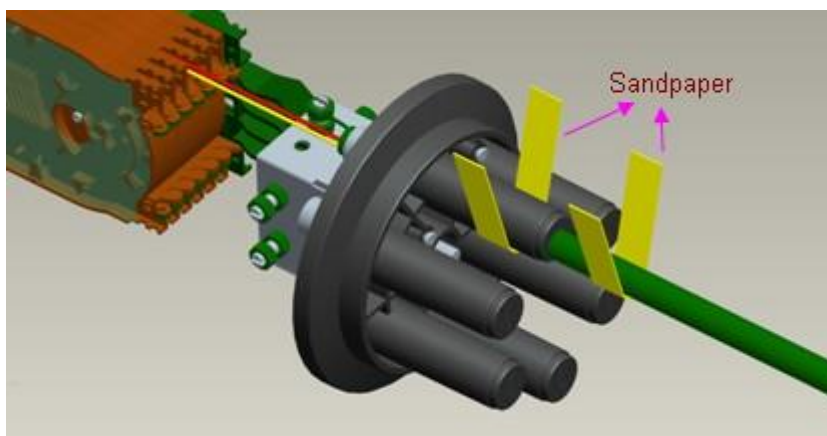

Heat shrink sealing

Twine the aluminum foil on cable, then put heat shrink tube; heating the tube, then finish the sealing.  
(See the picture)

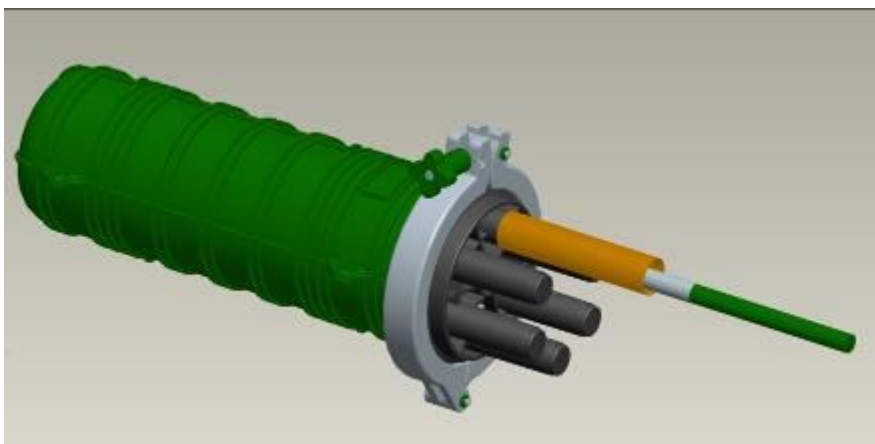

If entry/exit two cables, using fan out kit between two cables, then heating the shrink tube, finish sealing.

9. Check sealing & request.

- 1.The cable should be fixed by tie while entry splice tray.
- 2.The cover of splice tray should be closed.
- 3.Check the screws are fixed tightly.
- 4.Sealing accessories are in good condition.
- 5.The heat shrink tubes are fixed tightly.

10. Installation cover

- 1.Put the closure body together with closure base.
- 2.Install the hook, then fix tightly the body and base by screws.

Accessories:

Item	Name	Specification	Unit	Quantity
1	Heat protect sleeve	L=60mm	PCS	As per capacity
2	Cable tie	L=100	PCS	10
3	Heat shrink tube	Φ30*150mm, black color	PCS	6
4	Protect tube for bare fiber	Outside diameter 3mm	Meter	1
5	Insulating tape	Black color	roll	1

Optional accessories:

Item	Name	Qty	Remark
1	Pole mounted accessories	1	For pole mounted application
2	Aerial mounted accessories	1	For aerial using
3	Valve	1	For testing